

# POWER SPLITTERS

## For Removing Frozen Nuts The Right Way



### Features :

- Safe : No sparks. No flames. No risk to volatile surroundings. No hammers or impact needed. No flying fragments.
- Fast : Cuts a 3" nut in 20 to 30 seconds vs. approx. 20 minutes with a hammer & chisel or torch.
- Easy Set up : You can be up and away in less than 5 minutes.
- No Damage to bolt or stud threads by calibrating the chisel so that only the nut is cut.
- Versatile : Power splitters cut the hardest nuts. The range of models offered and the range of each model compares very favorably vs. the competition.

### Power Splitter

Model - AS-105  
to  
Model - AS-506

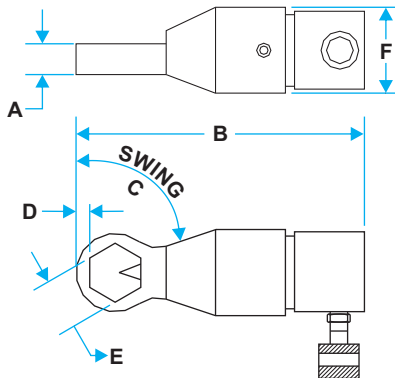

### Power Splitter Angle Headed

Model - AS-100AH  
to  
Model - AS-314AH

For removing  
Frozen nuts  
the right way.  
Other Anglesplitter  
sizes quoted on  
request.

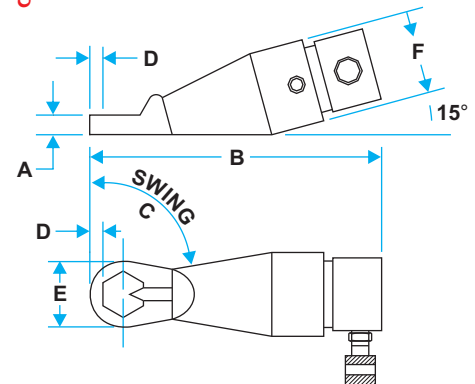

### Power Splitter

Model No.	Stud Diameter		Nut A/F 		A	B	C	D	E	F	Weight	
	mm	inch	mm	inch							mm	mm
AS-105	11 - 22	7/16 - 7/8	16 - 36	5/8 - 1.7/16	38	271	60°	10	38	105	9.82	21.60
AS-200	22 - 32	7/8 - 1.1/4	36 - 51	1.7/16 - 2	38	287	45°	13	54	108	10.42	22.90
AS-204	32 - 38	1.1/4 - 1.1/2	46 - 60	1.13/16 - 2.3/8	57	385	30°	14	64	164	32.50	71.50
AS-210	35 - 45	1.3/8 - 1.3/4	57 - 70	2.1/4 - 2.3/4	57	398	30°	18	73	164	32.86	72.30
AS-308	45 - 57	1.3/4 - 2.1/4	70 - 89	2.3/4 - 3.1/2	78	460	30°	19	99	214	72.12	158.66
AS-314	50 - 64	2 - 2.1/2	79 - 98	3.1/8 - 3.7/8	80	488	30°	22	108	214	74.52	163.94
AS-404	64 - 70	2.1/2 - 2.3/4	95 - 108	3.3/4 - 4.1/4	95	579	60°	29	118	251	114.18	251.20
AS-500	76 - 83	3 - 3.1/4	114 - 127	4.1/2 - 5	105	590	60°	29	137	251	116.62	256.56
AS-506	83 - 89	3.1/4 - 3.1/2	124 - 136	4.7/8 - 5.3/8	105	598	60°	29	149	251	119.50	262.90

### Power Splitter Angle Headed

Model No.	Stud Diameter		Nut A/F 		A	B	C	D	E	F	Weight	
	mm	inch	mm	inch							mm	mm
AS-100AH	11 - 16	7/16 - 5/8	13 - 24	1/2 - 1	17.5	190	30°	6	65	72	7	3.2
AS-105AH	11 - 22	7/16 - 7/8	16 - 36	5/8 - 1.7/16	38	280	60°	10	70	105	9	20
AS-200AH	22 - 32	7/8 - 1.1/4	36 - 51	1.7/16 - 2	38	290	45°	13	95	108	10	22
AS-204AH	32 - 38	1.1/4 - 1.1/2	46 - 60	1.13/16 - 2.3/8	57	410	30°	15	108	164	24	60
AS-210AH	35 - 45	1.3/8 - 1.3/4	57 - 70	2.1/4 - 2.3/4	57	420	30°	18	130	164	26	66
AS-308AH	45 - 57	1.3/4 - 2.1/4	70 - 89	2.3/4 - 3.1/2	78	500	30°	20	160	214	44	96
AS-314AH	50 - 64	2 - 2.1/2	79 - 98	3.1/8 - 3.7/8	80	510	30°	23	175	214	46	100

\* If you have an application not covered by the models above just call us and we will probably be able to design a model for you.

# POWER SPLITTERS

## Power Splitter Vs. the competition :

- Versatile : One model cuts a wide range of nut sizes (6-8) Vs. 1-2 of the competition. Hydraulic Cylinders and other common parts among models reduce inventory (refer parts list below for common parts).
- Flexible : Housing is designed to fit virtually any application so you can work from more angles and in tighter spaces. Power Splitter fits all API and ANSI flanges and all valve bonnets. It cuts virtually any shape nut (Hex, square and 12 point).
- Durable : Our heat treatment processes and cryogenic treatment of housings and chisels ensure life second to none. Chisels can be resharpened after dozens of cuts to prolong life.
- Precise : Chisel can be callibrated by using suitable holder to cut the nut wall precisely so that the bolt or stud does not get damaged. No damage to your equipment and no damage to your Power Splitter.
- Power : Power to weight ratio is the best in the industry and it is easier to handle.
- Economical : Price is among the most competitive available anywhere in the world.
- Warranty : For a full 6 months from defects in materials or workmanship.
- Variety of Pumps : Power splitter can be supplied with a variety of hand, foot operated, electric or air powered pumps.

Please contact us for choices of available pumps.

## Power Splitter Part List :

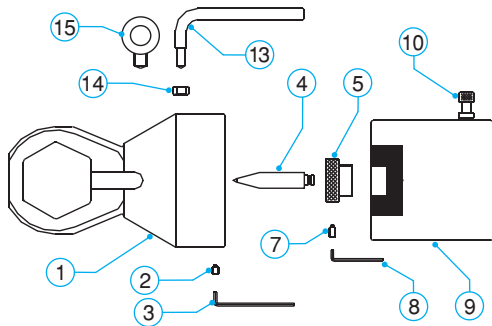

### TYPE 1

POWER SPLITTER with externally threaded chisel holders; used in nut splitters with internal threads in the piston rod.

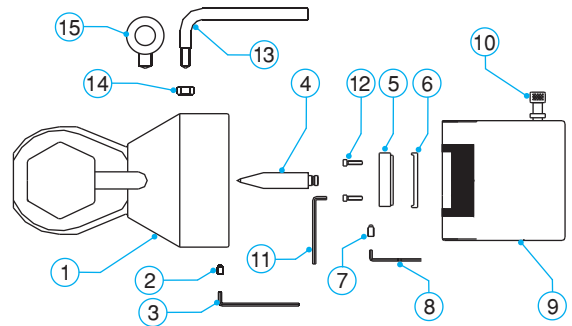

### TYPE 2

POWER SPLITTER that have a cylinder with threaded Bolt holes in the piston rod and chisels holders that use socket head cap screw.

Sr. No.	Description	Model									
		Type 1						Type 2			
		AS100	AS105	AS200	AS204	AS210	AS308	AS314	AS404	AS500	AS506
1	Housing										
2	Set Screw										
3	Allen Wrench										
4	Chisel										
5	Chisel Holder										
6	Spacers Set										
7	Set Screw for Chisel Holder										
8	Allen Wrench for Chisel Holder										
9	Hydraulic Cylinder										
10	Quick Disconnect Female Coupler										
11	Allen Wrench for Cap Screws										
12	Socket Head Cap Screw (2 each)										
13	Handle for Housing (2)										
14	Hex Nut for Handle (2)										
15	Lifting Eye										
16	Tool Box (Not Shown)										

Note : Shades overlapping into multiple model numbers indicate common parts.