

TORQUE MULTIPLIERS

Handtorque - Multipliers

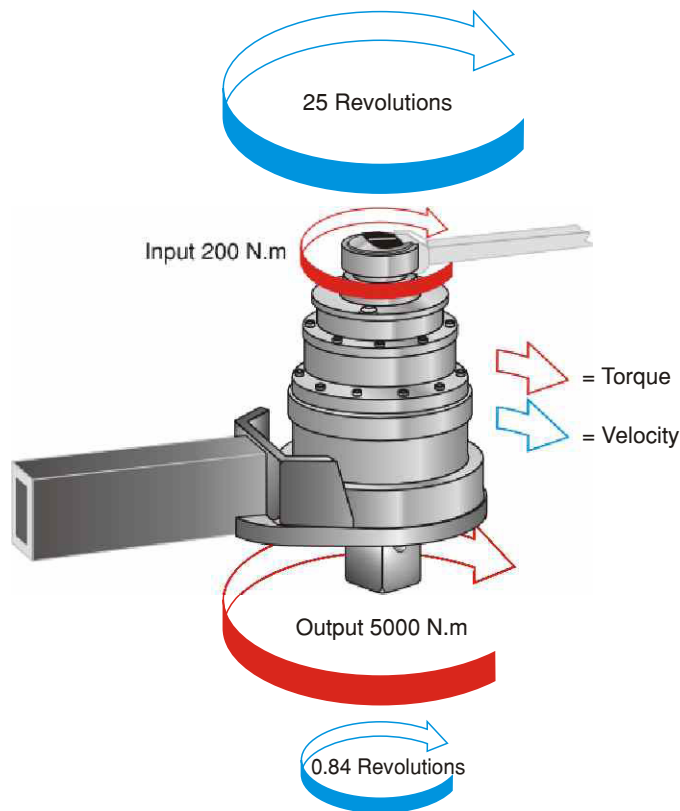

What is a Torque Multiplier?

A torque multiplier is a device that increases the torque that can be applied by an operator. Because the power output can not exceed the power input, the number of output revolutions will be lower than the number of input revolutions (Torque x rpm = Power).

How They Work

Handtorque multipliers incorporate an 'Epicyclic' or 'Planetary' gear train having one or more stages. Each stage of gearing increases the torque applied by a factor of 5, allowing Powermaster to offer multipliers in ratios of 5:1, 25:1 and 125:1.

In the planetary gear system, torque is applied to the input gear or 'Sun' gear. Three or four planet gears whose teeth are engaged with the sun gear and therefore rotate. The outside casing of the multiplier, or 'Annulus' is also engaged with the planet gear teeth, and would normally rotate in the opposite direction to the sun gear. A reaction arm prevents the annulus from rotating, and this causes the planet gears to orbit around the sun. The planet gears are held in a 'Planetary' carrier which also holds the outputs square drive. Therefore as the planetary gears orbit around the sun gear, the carrier and so the square drive turns.

Without the reaction arm to keep the annulus stationary, the output square will not apply torque.

Why use a Torque Multiplier?

Safety - Use of long levers can be dangerous. Torque multipliers mean a reduction in the lever length or operator effort by a factor of 5, 25 or 125.

Space Limitation - The use of a long lever may be impossible due to restricted space.

Accuracy - Torque will be applied most accurately when it is applied smoothly and slowly. Torque multipliers enable this by removing much of the physical effort from the tightening task.

TORQUE MULTIPLIERS

Advantages Of Powermaster Torque Multipliers :

POWERMASTER gearboxes are built to an extremely high standard of precision. All gears rotate on needle roller bearings about hardened and ground journal pins. As a result, POWERMASTER Torque Multipliers can be relied upon to have a torque multiplication accuracy of $\pm 4\%$, throughout the operating range, taking the uncertainty out of high torque tightening.

No gearbox is 100% efficient and so the velocity ratio (the number of turns that the input has to make to achieve one revolution of the output) is not the same as the torque multiplication ratio. POWERMASTER multipliers are engineered such that each gear stage has a velocity ratio of typically 5.45:1 which result in a true torque multiplication factor of 5:1.

Torque output calculations are therefore a matter of simple arithmetic with little risk of incorrect bolt loading due to conversion errors. Other manufacturer's often require graphs or formulae to calculate the input torque to achieve a particular output.

POWERMASTER Torque Multipliers are the most comprehensive multiplier range available. Standard products are available up to 47,500 N.m (35,000 lbs.ft).

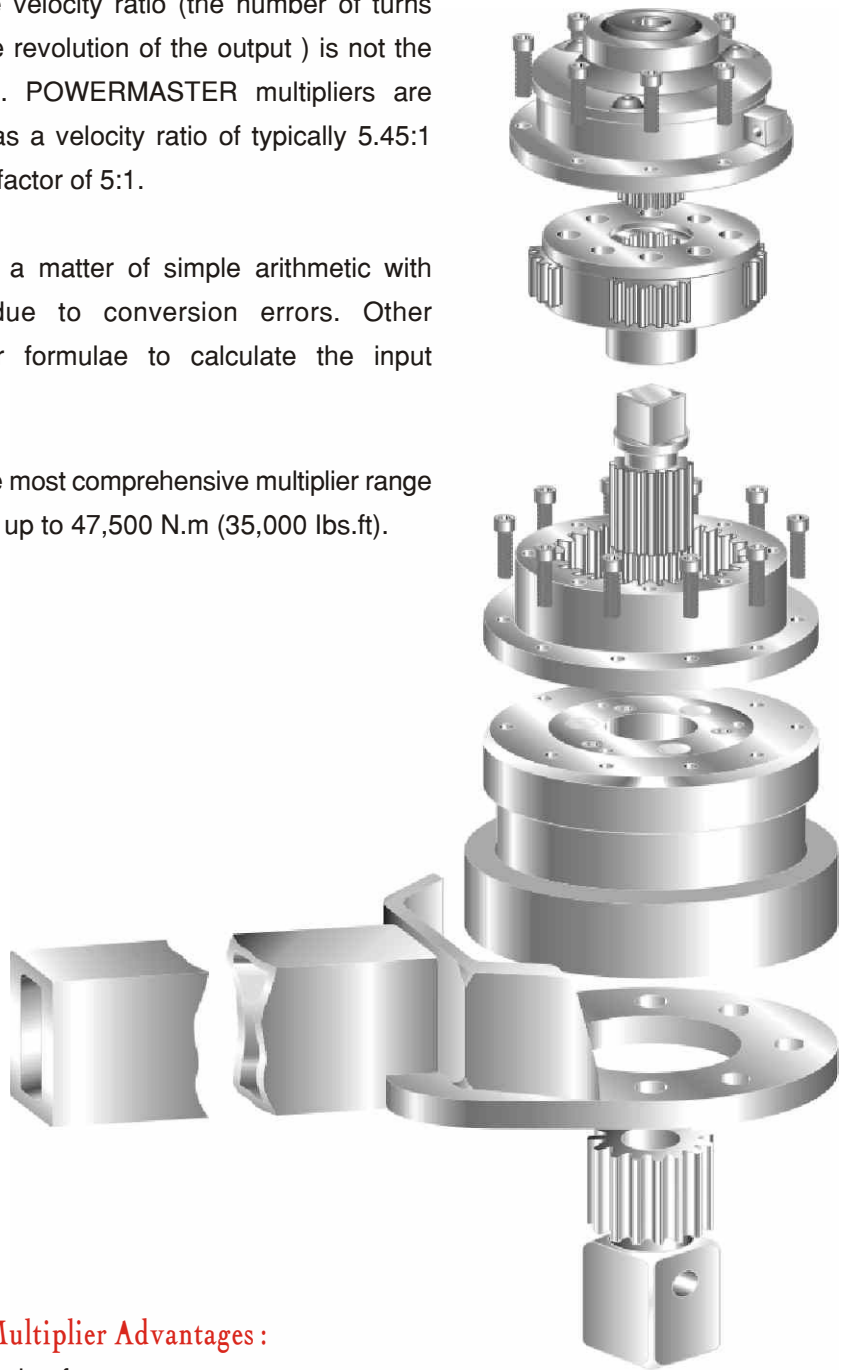

Summary Of POWERMASTER Torque Multiplier Advantages :

The ratio stated is the true torque multiplication factor.

No correction charts are needed to determine torque output.

Strong, safe Anti Wind-Up Ratchet available on most models for safe and comfortable operation.

A wide range of alternative reaction members are available making the Torque Multiplier adaptable to many applications.

TORQUE MULTIPLIERS

POWERMASTER Anti Wind-Up Ratchet (AWUR):

With any high ratio gearbox (25:1 or more) a certain amount of wind-up (spring) has to be taken up before any useful tightening work is applied to the nut.

Each time the input device is released, the wind-up will rotate it back against the direction of operation.

The Anti Wind-Up Ratchet retains all of the wind-up forces as they are created, with the following benefits :

1. The torque input device can not fly backwards against the direction of operation if it is suddenly released.
2. Without an Anti Wind-Up Ratchet, it will often be necessary to continue to make 360 sweeps with the torque input device otherwise the multiplier will 'unwind'. However, obstructions will often make this impossible.
3. With an Anti Wind-Up Ratchet fitted, the multiplier becomes locked onto the nut because the reaction plate is held hard against the reaction point. This means that even used upside down, the multiplier will support it's own weight.

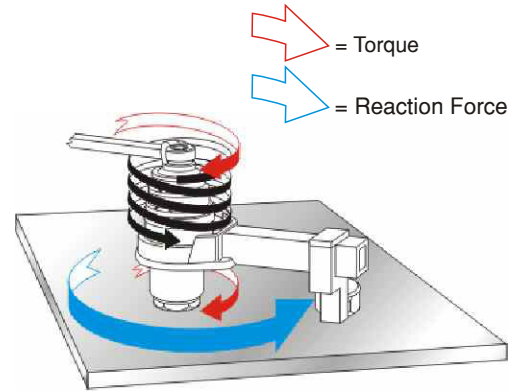

Multiplier behaves like a very stiff 'Spring'

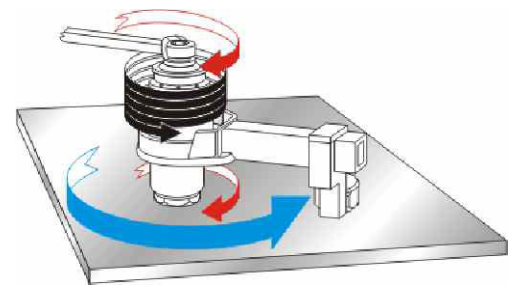

Multiplier will achieve maximum torque only after the 'Spring' has been taken up.

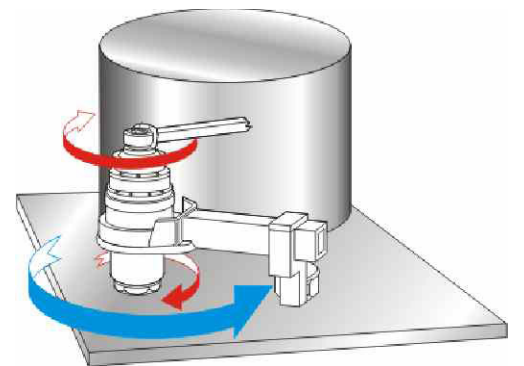

In this application, if it takes more than 180° to take up the wind-up at the required torque, this tightening operation will be impossible without an 'Anti Wind-Up Ratchet'.



◀ *Standard Series Anti Wind-Up Ratchet.*

Safety Note : Additional support is recommended as failure in the bolt, socket or multiplier will release the wind-up forces and cause the multiplier to drop.

TORQUE MULTIPLIERS

Handtorque - Standard Series

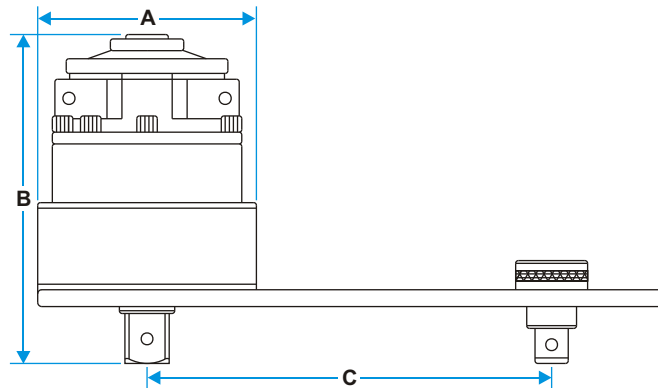

Handtorque Standard Series to 3400 N.m : **HANDTORQUE** 3400 N.m.

- Accuracy better than $\pm 4\%$.
- Precision tightening and loosening of all heavy duty fastening connections.
- Low energy input with high torque transfer.
- Multipliers are furnished with strong ratchets (anti-wind up) allowing jobs to be performed easily, efficiently, and safely.
- Precision Manufacturing ensures long life and premier quality.
- Shear pin at input drive protects gear box in case of torque overload.
- Highest possible load factor is guaranteed due to design and use of forged components.
- Each tool contains extra shear pins, and torque multiplication selection sheet.

Standard Series, to 3400 N.m

Model No.	Range		Ratio	Input Square	Output Square	A Ø	B	C min	C max	Weight*	
	N.m	lbf.ft		inch	inch	mm	mm	mm	mm	kg	lbs
BTM-1	1700	1250	5	1/2	3/4	115	115	82	210	4.50	9.90
BTM-2	1700	1250	5	3/4	1	115	130	82	210	5.00	11.00
BTM-2/25	1700	1250	25	1/2	1	115	151	75	164	7.00	15.40
BTM-5	2700	2000	5	3/4	1	136	135	89	260	8.40	18.48
BTM-5/25 Fitted with AWUR	2700	2000	25	1/2	1	136	163	89	260	11.50	25.30
BTM-6	3400	2500	5	3/4	1.1/2	136	149	105	260	9.20	20.24
BTM-6/25 Fitted with AWUR	3400	2500	25	1/2	1.1/2	136	176	105	260	12.00	26.40

* Including reaction plate.

TORQUE MULTIPLIERS

Handtorque - Standard Series

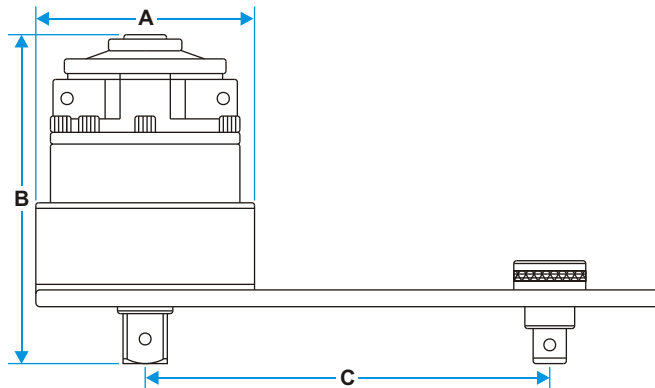

Handtorque Standard Series to 47500 N.m : **HANDTORQUE** 47500 N.m.

- Accuracy better than $\pm 4\%$.
- Precision tightening and loosening of all heavy duty fastening connections.
- Low energy input with high torque transfer.
- Multipliers are furnished with strong ratchets (anti-wind up) allowing jobs to be performed easily, efficiently, and safely.
- Precision Manufacturing ensures long life and premier quality.
- Shear pin at input drive protects gear box in case of torque overload.
- Highest possible load factor is guaranteed due to design and use of forged components.
- Each tool contains extra shear pins, and torque multiplication selection sheet.

Standard Series, to 47500 N.m

Model No.	Range		Ratio	Input Square	Output Square	A \emptyset	B	C min	C max	Weight*	
	N.m	lbf.ft		inch	inch	mm	mm	mm	mm	kg	lbs
BTM-7	6000	4500	5	3/4	1.1/2	168	174	115	310	18.00	39.60
BTM-7/25 Fitted with AWUR	6000	4500	25	1/2	1.1/2	168	226	115	310	22.00	48.40
BTM-9/25 Fitted with AWUR	9500	7000	25	3/4	1.1/2	195	256	150	350	33.00	72.60
BTM-9/125 Fitted with AWUR	9500	7000	125	1/2	1.1/2	195	301	150	350	35.50	78.10
BTM-11/25 Fitted with AWUR	17000	12500	25	3/4	2.1/2	220	360	164	480	52.00	114.40
BTM-11/125 Fitted with AWUR	17000	12500	125	1/2	2.1/2	220	404	164	480	57.00	125.40
BTM-13/125 Fitted with AWUR	47500	35000	125	3/4	2.1/2	315	550	164	480	80.00	176.00

* Including reaction plate.